

Device for Affixation of Rear-Facing Child Restraint System to Ambulance Cot for Non-Emergent Transportation

Kendall Rogoff, Lily Buchanan, Troy Kohler, and Matthew Miller

Biomedical Engineering Capstone Design, Spring 2021

Union College, Schenectady NY



Background

The need for proper child restraints during motor vehicle travel is clear; motor vehicle crashes are the leading cause of unintentional death for children over 1-year-old [1,2]. Despite the overwhelming evidence that car seat use reduces injury and mortality during motor vehicle travel by up to 70%. As discussed below, toddlers and infants are rarely transported in ambulances in compliance with national guidelines [3-5]. Ambulance crashes are rare, with only about 10,000 a year across the United States [6]. As a comparison, there are approximately 6.76 million police-reported traditional motor vehicle crashes a year [7]. With approximately 6 million children transported in emergency vehicles per year and a crash rate of 7-17.1 per 100,000 transports, up to 1,000 children are involved in ambulance crashes each year [6,8].

Data about pediatric injuries related to ambulatory transport services is restricted to anecdotal reports; however, in a limited study examining pediatric transport over one year, no children under 3 were correctly transported despite 75% of the interviewed Emergency Medical Services (EMS) members describing their knowledge of pediatric transport as ‘adequate’ [9, 10]. This disconnect between the assumed understanding of safety needs and actual actions highlights the need for an instructional element in our product.

Evaluating ambulance use in the United States is complicated by complete deregulation at a federal level: the legal role and regulation of EMS vehicles are entirely decided at the state and local levels. Broad geographic and socio-economic differences across the country combine with a complex and highly privatized medical system means that the role of EMS heavily varies across communities. Inconsistent legal requirements also further add to the differences in what EMS does across state and local levels. Federal agencies, such as the National Highway Traffic Safety Administration (NHTSA), release limited guidelines for ambulances (and associated

pediatric transport) but do not have any legal power to enforce those guidelines. The opposite is true for child restraint systems (CRS), also known as car seats, which follow strict federal statutes. Car seats must meet material, integrity, occupant excursion, injury criteria, and deformation standards, resulting in a consistent and secure environment for children [11].

Societal confidence in car seats is high: even among parents who do not own cars, ownership of child safety seats approaches 90% [12]. While only 5.7% of children are uninsured on a national level, a much larger number are underinsured, meaning they have continuous coverage, but it does not cover enough that their families are able to afford their healthcare needs.

For people in urban or suburban areas, such as the Capital Region surrounding Albany, NY with limited access to routine primary care, such as uninsured or underinsured individuals and families, EMS serves as part of the health care safety net [13-15]. While only 5.7% of children are uninsured on a national level, a much larger number are underinsured, meaning they have continuous coverage, but it does not cover enough that their families are able to afford their healthcare needs. 43% of adults are estimated to be inadequately insured as of 2020, and those adults are likely to enroll their children in public insurance regardless of adult insurance type [16,17]. Children from families that have mixed insurance types, inadequate private insurance, or are uninsured are all significantly less likely to receive routine primary care than those from families with full coverage public or private insurance [17]. Therefore, pediatric patients with conditions that would normally be addressed by a pediatric primary care provider, such as a fever or cold, are instead brought to the emergency department [13,15]. This creates a gap in the current market, which does not currently have a device associated with transportation where the children do not need active care in the ambulance.

In the Capital Region, if ambulances are equipped with devices to aid with pediatric transport, it will be one of two devices: the Pedimate or ACR-4 [15]. Both devices are harnesses, meant to strap the infant or toddler to the cot while they lay on their back [18,19]. These devices excel at keeping the patient secure while they receive urgent prehospital treatment. For patients that do not need pre-hospital care, such as those with fevers and colds, it often seems pointless from both a parental and EMS perspective to strap down a fussy infant [15]. The reduction in fatalities and injuries associated with proper car seat use in motor vehicles supplies compelling evidence that it is important to find an alternative to the little-used harnesses. This alternative will be based on the use of the reliable and trusted infant car seat and will therefore be more appealing to parents of infants not requiring pre-hospital care as well as the technicians transporting them.

Problem Statement

Current devices on the market for pre-hospital infant transports do not utilize crash-tested rear-facing child restraint systems, therefore young children and infants often go unrestrained in ambulances. Our goal is to provide a solution to this by creating a universal, sanitary, and NHTSA compliant device that rapidly enables the appropriate securement of an infant in a rear-facing child restraint system to an ambulance's cot.

Device Customer Requirements

Customer requirements for this project focus on ensuring the safety and compatibility of the device, in addition to being simple, inexpensive, and compact. These can be seen in the full Quality Function Deployment (QFD) in Appendix A and are summarized below in Table 1.

Table 1: Critical Customer Device Requirements

Maintains infant safety through secure attachment
Adaptable to cot and child restraint seat
Affordable
Compact design
Ease of Use

Safety is the most important requirement. If the product is not at least as safe as the competitors, it will never be used. Therefore, the proposed product will keep the tested and trusted level of safety of a rear-facing child restraint system despite being adapted to a new scenario.

Another focus of the customer requirements is compatibility. Different cot brands and types are used in different ambulances across the United States, but there are two different cot brands, Stryker and Ferno, that are used in the Capital Region of New York [15]. Within each brand the stretchers are similar, so if the device is compatible with each brand, it should be compatible with most transports and ambulances. This will ensure it reaches the widest possible market. The device must work with most brands and models of rear-facing CRS. Common design features across CRS brands and models will aid in the construction of a universally applicable device.

Additionally, ambulances are limited on equipment space, and all equipment in the ambulance must be secured in place unless it is being used. This imposes a strict size requirement on the device since it cannot take up space compared to more utilized lifesaving equipment. In addition, it must be able to be secured and stored to prevent it from becoming a projectile and injuring someone in the ambulance. Ambulance cots often have space underneath the bed of the cot, in which the device can be stored and deployed from. This space is relatively small, so any device here must be flat and correspondingly small.

The device must be simple. Treating the patient is the EMT's highest priority, so they will spend time installing over-complicated equipment. This simplicity will minimize the cost of the device, which is crucial since it will not be used very often and will have to compete with other devices currently on the market.

The rest of the customer requirements establish guidelines on the longevity of the product and failure modes of the device, and can be seen in Appendix A. It is vital for the customer to be able to know when the device is securely attached or is in need of replacement.

Device Functions

The functional decomposition of the device functions can be seen below in Figure 1. Mechanical force is used to secure the device to a CRS and to an ambulance cot. The attachment mechanism will use the most secure points on the cot for attachment and use the existing attachment points of the rear-facing child restraint system. This is broken down into the cot and car seat attachments, which can use the various mechanisms. The storage of the device must be secure under the cot and not impede normal usage of the cot. Attachments cannot impair the structural integrity of the cot or CRS because it would impede safety, and both need to be reused for prolonged periods of time.

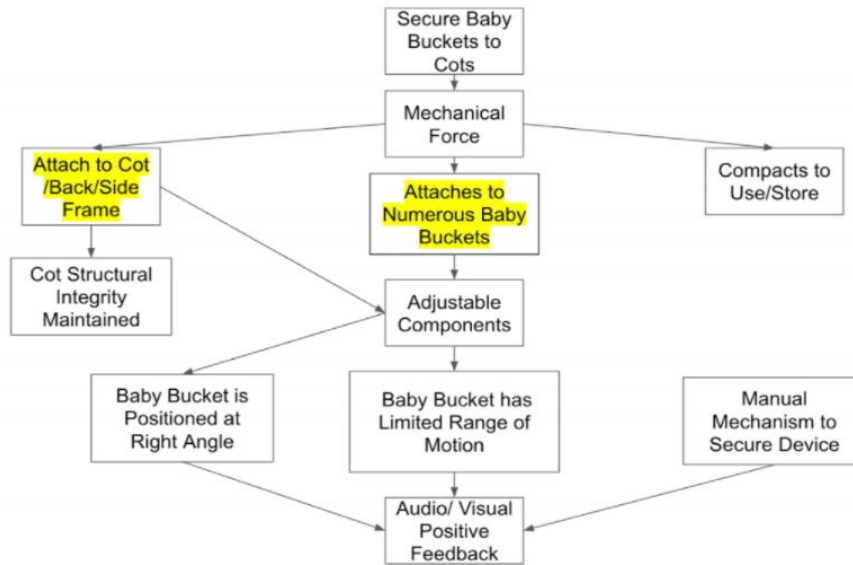

Figure 1: Functional Decomposition of Stork SD-1

The components of the restraint system will need to adapt to different models and styles of CRS and should utilize common design features. It will also need to properly limit the movement of the car seat on the stretcher, so it does not move in a crash. This involves preventing lateral movements and tipping. Since a CRS must be positioned at a particular angle to ensure the infant is best able to breathe, a mechanism must be included in order to ensure an infant is at the optimal breathing angle [20]. All components will have an audible or visible feedback mechanism to indicate their correct usage and must be compact. For example, the straps have an audible click when the buckles are secured together, and the straps are color coded to ensure they are implemented correctly.

Design Specifications

Multiple design specifications were established for the proposed securement device in consideration of the customer requirements noted in the QFD process [Appendix A]. These

specifications will aid in the successful fabrication of the product and will ensure that the customer needs are met and verified through subsequent testing procedures.

Customers described the need for a device that is universal, emphasizing its ability to work with rear-facing child restraint systems (CRS) of different shapes, sizes, and brands as well as the differing cot types within ambulances. This gave rise to the most important design specification: that the Stork product is compatible with a minimum of 5 rear-facing child restraint systems (RF-CRS) and 2 ambulance cot brands. There are two brands of cots used within emergency transport vehicles, Stryker and Ferno, and this design specification covers the Stork product's use across both platforms. Additionally, there are similarities between the brands of RF-CRS that can be utilized to ensure the universality of the Stork device.

A second design specification generated from the customer requirements is that the Stork products can be assembled and disassembled in 2-5 minutes. The aspect of efficiency of use for this product arises from the need for this product to compete with the existing products on the market as well as ensure quick deployment in the context of emergency transport. By having a quick assembly and disassembly time, the Stork product becomes more desirable to the customer investing in it.

Not only is efficiency an essential aspect of the Stork product, but accessibility is as well. To make the product cost-effective for EMS personnel, it must cost less than \$200 per unit. This price is competitive with the prices of competitor products on the market, the Pediamate, and ACR4, which cost \$400 and \$845 respectively [21,22]. This specification arose from the need to develop a desire for the Stork product compared to existing securement devices, not only from a uniqueness aspect, but from a cost perspective as well.

Most importantly, the Stork securement device must be safe for the patient to travel in. The purpose of this device is to attach and transport an infant in the safety of their child restraint system via an ambulance. As a result, the RF-CRS will laterally shift less than 1” and rotate towards the vertical no more than 20° when attached to the ambulance cot. This value arises from the existing verified constraints placed upon the RF-CRS, installed in motor vehicles, by the Federal Transport Law [23]. Not only does this ensure the RF-CRS is being transported safely, but that in the event of excessive movement the Stork device is equipped to sustain the same forces.

The four specifications described define the use and goals of the Stork product in terms of the market it will exist in and the uses it will have. Additionally, these specifications can be tracked and tested to ensure the customer needs and requirements are sufficiently met by this product.

Final Design

The final design for the Stork SD-1 is an effective, efficient, and intuitive solution for the attachment of a RF-CRS to an ambulance cot. Overall, the design can be broken down into two major subsystems: the base and the strapping pattern, which execute the customer requirements previously established through the product development process. In terms of efficiency, a limited number of straps were used to ensure EMS personnel are able to learn the device quickly and implement it under the desired time constraint of 2 minutes. This design focuses on utilizing the universal features present on all RF-CRS and ambulance’s cots to enable the use of this product on a multitude of products. Additionally, all the straps featured in the final design are ambulance cot-grade straps which contributes to the known effectiveness of the design. This final design

was chosen to be pursued because it can be installed with an infant in a RF-CRS, can remain on the ambulance cot at all times, and is simple to assemble.

The main feature of the final SD-1 design is the base subsystem. This subsystem is composed of a circular metal plate (diameter of 7" and thickness of 0.125") with cutouts dimensioned to fit standard ambulance cot strap widths.

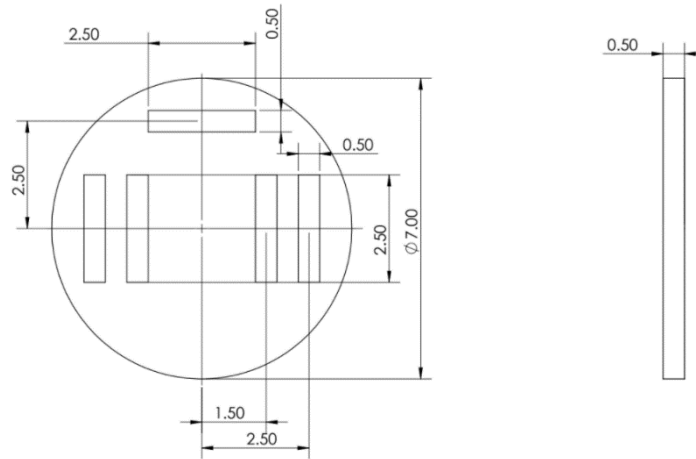
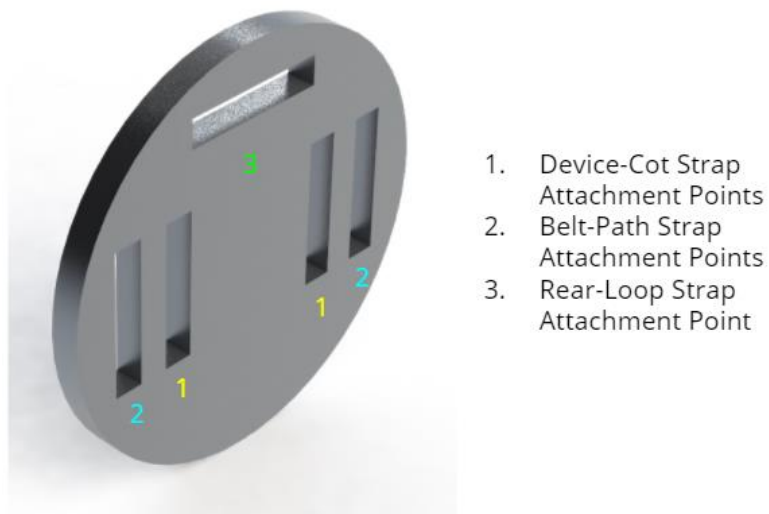

Figure 2. Base Subsystem Design Drawing with Dimensions

The location of these cutouts is based upon the developed strapping pattern and their designations are indicated in the legend of figure x.



1. Device-Cot Strap Attachment Points
2. Belt-Path Strap Attachment Points
3. Rear-Loop Strap Attachment Point

Figure 3. Strap Cut-out Designations

June 2021

A key feature of this design is that the base is composed of a material that can be reusable and easily sterilized if needed and can remain underneath the cot once attached as the metal will not degrade over time, solving the problem of a lack of storage within the ambulance. Additionally, the simplicity of the design allows for quick familiarity of the base by EMS personnel and lowers manufacturing costs keeping the product inexpensive.

The strapping pattern subsystem of the SD-1 design features three straps that integrate to tightly secure the RF-CRS to the ambulance cot. Figure x showcases the full strapping pattern.



Figure 4. Complete Strapping Pattern of RF-CRS on Cot

All straps are attached to the base subsystem through a looping method, making them all removable and replaceable in the event they get damaged, become unsterile, or need to be adjusted. The first of the straps used is the Device-Cot strap, designated a blue color. Its role is solely to attach the device to the ambulance cot, allowing it to remain on the cot until implementation. To accomplish this, a standard ambulance cot strap is wrapped around the side rails of a cot and tightened until taught. This keeps the device stored out of the way of EMS personnel, prevents the device's interaction with other objects, and is securable to any cot type regardless of size or brand due to its adjustability.

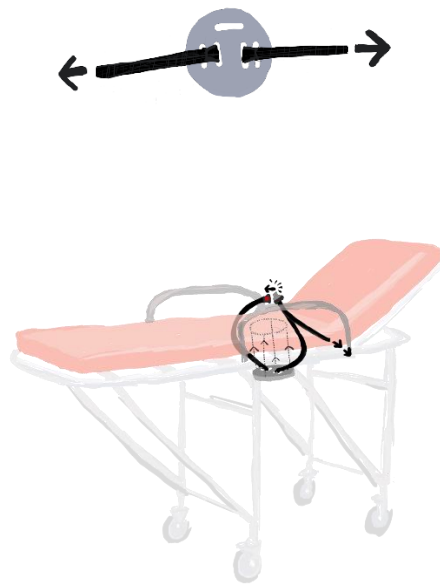

Figure 5. Device-Cot Strap Attached to Base

The second of the three straps within this subsystem is the Belt-Path Strap, assigned a black color. This strap utilizes the existing belt path present on all RF-CRS as this area is rated for the forces associated with external securement and can accommodate a variety of strap thicknesses. In the final design of this device, an ambulance cot strap is wrapped around the sides of the RF-CRS, fed through the belt path, buckled, and tightened as taught as possible, pushing the RF-CRS down into the cot bedding. Overall, the path for this strap was chosen since it is easy to install, it does not obstruct the infant in the RF-CRS and is universally applicable to all RF-CRS brands and types.

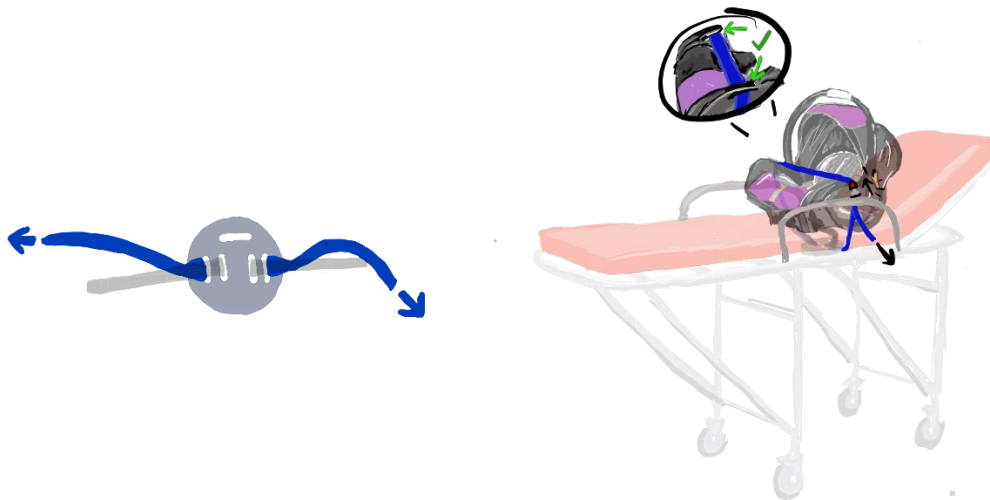

Figure 6. Belt-Path Strap Attached to Base and RF-CRS

The final strap used to secure the RF-CRS is the Rear Loop Strap, designated in orange. In this design, there is a rear strap that wraps around the head of the stretcher with a second strap forming a large loop through the end. The larger loop, lined with rubber to prevent slipping, wraps around the front of the RF-CRS and is tightened to prevent the forward tipping of the RF-CRS when the ambulance is moving. Finally, the rear strap is tightened to add additional tip-prevention and pull the RF-CRS further back into the cot bedding. This strapping pattern is again universally applicable and is implementable while an infant is in the RF-CRS.

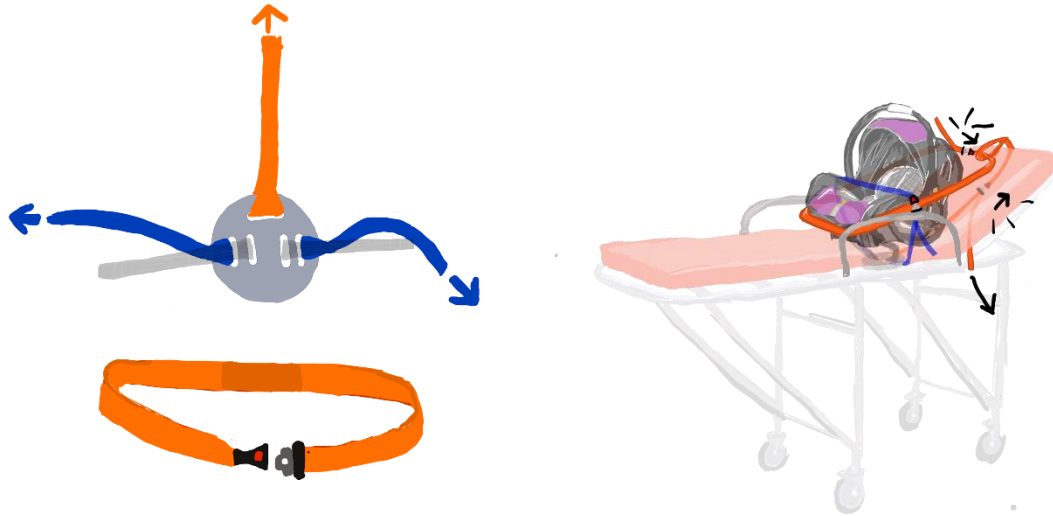

Figure 7. Rear-Loop Strap Attached to Base and RF-CRS

Altogether, the strapping pattern and base developed for the final design of this device effectively secures the RF-CRS to the ambulance cot quickly, intuitively, and safely while preventing the obstruction or removal of the infant from within their RF-CRS.

Final Prototype

Over the past 20 weeks, through research, design iterations, and testing, the developed product fulfills the needs established by our problem statement. The device is made of two subsystems: a base plate and three associated straps. The aluminum base component was fabricated via waterjet using the Solidworks model detailed in the above section. Figure 8, below, shows the final circular aluminum piece, with five cutouts for the strap components.

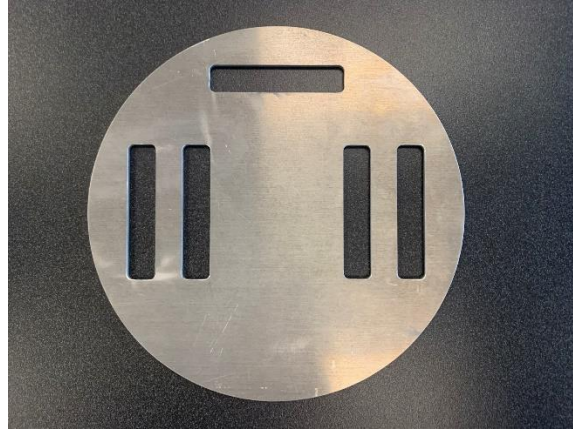

Figure 8. Aluminum Prototype of Base Subsystem

The three strap components are made of five elements, the technical specifications of which are detailed below in Table 2.

Table 2: Subcomponents of final device

Item	Manufacturer	Price via. secondary distributor	Material	Dimensions	Features
Device-Cot Strap (DCS)	Morrison Medical #1200BK	\$16.95	Black nylon, 4000lb break strength	Length:5 ft. Width: 2 in. Weight: 0.8lbs	Loop lock ends, metal push button buckle
Belt-Path strap	DMS #31162 BL	\$12.95	Blue impervious nylon	Length: 6 ft. Width: 2.5in Weight: 0.5 lbs	Loop lock ends, metal push button buckle
Rear strap	DMS #11152 OR	\$12.80	Orange nylon	Length: 5ft. Width: 2.5 ft. Weight:0.45 lbs	Loop lock ends, metal push button buckle
Loop strap	DMS #11071 OR	\$12.63	Orange nylon	Length: 5ft. Width: 2.5 ft. Weight:0.57 lbs	Metal push button buckle
Rubber strip	Grainger BULK-RS-S40-792	\$5.67	40A Red silicone	Length: cut to size Width: 2 in. Thickness: 1/16 inch	Elongation: 400% Tensile Strength: 1000 PSI

All of the individual components detailed in Table 2 are combined to form the final device. The base affixation strap attaches to the base (Figure 9) and then wraps around the stretcher (either over or under the bedding), putting the base in an ideal position for implementation of the further straps (Figure 10).



Figure 9. Device-Cot Strap Attached to Aluminum Base



Figure 10. Device-Cot Strap Attached to Ambulance Cot

The blue belt-path strap goes across the namesake belt path of the CRS once it is placed on the cot, on top of the base affixation strap. It also attaches to the base plate (Figures 11-12).



Figure 11. Belt Path Strap Attached to Aluminum Base



Figure 12. Belt Path Strap Securing RF-CRS to Ambulance Cot

The rear strap is the final strap that interacts with the aluminum base, as shown in Figure 13. The looping strap wraps around the front of the CRS and through the available loop lock end of the rear strap (Figure 14-16). Both the belt path, looping, and rear straps should then be tightened to appropriately secure the CRS. The first rubber segment should run along the front of the CRS on the loop strap, approximately parallel to the blue belt-path strap. The second rubber piece sits next to the loop at the end of the rear strap, atop the back of the stretcher.

In total, the straps weigh 2.32 lbs, or just over 1kg, with a negligible weight added from the rubber components.



Figure 13. Rear-Loop Strap Attached to Aluminum Base

In addition to the device itself, the SD-1 includes an accompanying instructional installation pamphlet, included as Appendix B.



Figure 14. Full Strapping Pattern Assembly



Figure 15. Rear-Loop Strapping Arrangement



Figure 16. Rear-Loop Path Across Ambulance Cot

Design Validation

In order to validate the final design of the SD-1, the securement device was put under a mock crash test to observe the way a CRS is restrained to the cot under sudden changes of acceleration and forces that would be present in an ambulance. To simulate a crash test, a cot was attached to the tow hitch of a car using a tow strap before being let go of on a hill, which caused the cot to roll down the hill before being stopped by the strap becoming taut with tension. Once the strap became taut the cot would suddenly stop and rapidly decelerate. The cot was allowed to roll down the hill front facing and backwards to create two different experimental groups. Tests were performed with two different CRS, one Chicco and one Graco, to test the securement device's universality. Each CRS was rolled down the hill forwards three times and backwards three times for a total of 12 different trials. Each trial was recorded at 240 fps in 1080p, which was then analyzed using a Tracker Software for frame-by-frame analysis to

determine the movement of the CRS. The distance was found by performing point mass analysis of a slow-motion video of the cot jerking backwards due to the tow strap. The point mass was located on a piece of tape that was put on each of the two models. The coordinate value of the initial starting point of the point was subtracted from the maximum coordinate point to determine the distance the CRS moved. The video was analyzed every 5 frames and the distance of the rail was used as a reference value for the movement of the CRS, as shown in Figure 17. Additionally, a baby doll weighing 12.3 pounds was put into the CRS to simulate a child being present in the CRS. An accelerometer was also placed in the CRS to determine the force the child would experience.



Figure 17: The image on the left demonstrates the initial starting point for the positional video analysis, it also shows the reference scale that was used to create the coordinate system for the analysis. The image on the right demonstrates the point mass analysis that was used to track the movement of the CRS as a result of the stopping force.

As a result of testing, the securement device in the ways described above Table 3 was found with the average peak force experienced by the child during the crash test for both CRSs and going forward and backwards in the cot.

Table 3: The maximum average force experienced by the doll in the CRS during testing. The average value was calculated from all three different trials for the specified test that was performed.

Experimental Group:	1.1 (CRS 1 Forward)	1.2 (CRS 1 Backward)	2.1 (CRS 2 Forward)	2.2 (CRS 2 Backward)
Max Average Value (g _n):	8.283	5.185	10.319	9.258

After performing video analysis via the Tracker Software, an average peak distance moved in both the x and y direction was found, as shown in Table 4. When using the first CRS, the Chicco model, the device moved its most during the tests where it was sent down the hill backwards, with a maximum distance of 2.124 inches in the x-direction. The second CRS, the Graco model, saw higher amounts of movement when tested with a maximum distance moved of 3.396 inches moved in the x-direction.

Table 4: This table contains the values of the average peak movement in inches in the x and y directions for the varying CRSs and cot configurations used in the experiment.

Device Validation:

Experimental Group:	Average x-direction Movement (in.)	Average y-direction Movement (in.)
1.1	0.827	0.312
1.2	2.124	0.375
2.1	3.366	3.01
2.2	3.396	1.204

After performing the initial testing of the device, the results provided valuable information that was very promising for the functionality of the device. When performing the video analysis it became clear that at a sudden stop the cot jerks in motion, but the device did a good job at maintaining that the CRS is in place and in contact with the cot. As a result of this the infant patient should remain safe because they are in a secure location in the back of the ambulance especially compared to previous models of transport. The overall lack of movement

of the CRS when the crash was initiated was the most promising. Using the proper installation steps of the securement device seemingly allowed the CRS to remain on the cot even during more extreme conditions than it would typically face in an ambulance.

The tests that were performed did have some limitations. One of these issues was the test that was performed was meant to stimulate a crash of an ambulance, however, in the back of an ambulance a cot is more secure than in the tests that were performed. The cot would be more secure in the ambulance because of the rail system that is used to lock the wheels and the cot securely to the floor of the ambulance. So, the fact that the CRS remained attached despite this was encouraging. However, one downside was that the child, at a peak, experienced a momentary force of 10.319 g, which is high. The largest consideration of this force though is that it was not a sustained force and it was a momentary force. Meaning that the child for a brief period of time experienced this force before returning to a more normal period of force sustainment. An additional consideration would be that the accelerometer was not secured in the CRS the same way a child would be using the harness straps within CRSs. One way to ensure that the child would not undergo any injury at this level of force would be to look at the head injury criteria, HIC, which is found using Formula 1 [Appendix C]. The purpose of this criteria is to determine the chance of a head injury during the peak exposure to high forces, specifically the 15 ms surrounding the peak exposures. For example, looking at trial 2.1c, the peak force the child was exposed to was 9.82g. Using Formula 1, this would result in a HIC value of 4.59. This HIC value indicates that a chance of injury is negligible [Appendix D], which is encouraging for the Stork SD-1. The HIC and acceleration analysis for the remaining trials is located in Appendix E.

Ethical Considerations

Ethics are an important part of engineering and must be thoroughly evaluated during the product development process. It is the responsibility of the team to make sure all processes abide by good engineering ethical standards. Therefore, throughout the development of the Stork SD-1, numerous ethical concerns were taken into consideration, including: the safety of the infant patient, the safety and securement of the device to ensure EMS member safety, abiding by NHTSA guidelines, limiting the waste associated with this product by making it as reusable as possible.

One of the largest ethical considerations led to the development of the Stork SD-1: maintaining the safety and wellbeing of the infant patient first and foremost. As the design developed, the aspect that remained most consistent was utilizing the rear-facing CRS as the place to hold the child. Modern CRSs that are developed are put under numerous safety tests and regulations, therefore, the safety of the child is guaranteed as long as the device is used and installed correctly. The proper securement of the SD-1 to an ambulance's cot is also paramount to ensuring the safety of all EMS personnel within the ambulance. As a result of these considerations, the Stork SD-1 is not loose in the back of the ambulance but rather it is secured to the cot at all times.

Another ethical consideration that was kept in mind during the design process was trying to limit the waste that was produced with this device. One of the issues with devices in ambulances is they are often exposed to bodily fluids and as a result either need to be cleaned or thrown away. As a result, the SD-1 has a reusable base that can be wiped clean and single use straps composed of a nylon material, moving forward using straps that could be used multiple times would limit the amount of waste that the device outputs.

Lastly, one area of ethical consideration that was essential to the design process was ensuring that the Stork SD-1 met the requirements to be considered NHTSA certified. In ambulance's NHTSA guidelines do not apply as a result of the vehicle being an emergency vehicle, however, to ensure the safest product for customers and patients, meeting the NHTSA guidelines was an important consideration during the entire design process.

Anticipated Regulatory Standard

According to the associated standards for seat belts, the base attachment of our design must be free from burrs that can potentially cut the material of the belt. The belt itself has to be sewn or treated so that it does not unravel and must also be marked with the manufacturer and date of manufacture. Another vital piece of this guideline is the need for the material to be resistant to microorganisms in the webbing. Considering the potential for our device to be exposed to bodily fluids it is essential to meet this guideline. [26] The straps must also meet the guidelines outlined under Standard FMVSS No. 213 [23] in which the straps must not degrade in color or strength from sunlight, nor from abrasion of the strap. NHTSA also requires that the car seat straps be able to withstand a breaking strength of at least 15 kN.

The most important standard for the RF-CRS is the 1-inch movement test. [26] This establishes that the CRS does not move more than 1" during installation while attempting to move the bucket. Another important standard was the need for the RF-CRS to be level on the surface it is mounted to, indicated by a level indicator present on the labeling of all CRS.

The RF-CRS must be secure enough on the stretcher that an accelerometer inside the test infant's thoracic region does not exceed 60 g's unless the interval is shorter than 3 ms. The head must also be limited to 1000 g's or less over 36 ms time interval to prevent brain injury. This will

June 2021

be an important stage of later testing to ensure that our device meets the stringent NHTSA regulations for car seats since there are few guidelines on ambulance child safety. Lastly, the back support angle of the CRS cannot exceed 70 degrees from the vertical position during testing.

Future Work

In the immediate future, the product requires further validation through comparison to a control dataset involving the metrics of an unrestrained infant experiencing sudden acceleration change. In addition, expanding our testing protocols to include higher levels of peak acceleration and deceleration will allow the approximation of how the device would perform in an actual crash scenario.

Looking to the long- term future, there are several pathways for further development of the SD-1. This term, the potential for this device to become reusable was discussed, and is a clear possibility moving forward. The strap connections could be modified to facilitate interchangeable single-use straps into a reusable base like the current material of the belt-path strap.

The other clear path is development of manufacturing and distribution procedures and protocols associated with the product. The current device cost \$61 in parts, with additional costs anticipated for the manufacturing of the metal base, which we sourced at no cost for this iteration. The current device cost \$61 in parts, and the aluminum was acquired, and water jetted free of charge. By working with a company such as Morrison Medical or DMS, the cost will be reduced by cutting out the secondary distributor (which in this case was Grainger), as well as allowing the straps to be customized with rubberized elements. The Solidworks model can easily be used by any machine shop already utilized by AMC to fabricate the aluminum base.

The assembly of the product- the combination and packaging of the straps, the base, and instructional pamphlet, would then be carried out by a trained AMC or EMS professional, and then distributed to ambulances regionally.

The products currently on the market to restrain children in ambulances are designed for emergency care. However, many infants do not need extensive care during transport. Facilitating the use of a CRS to secure the infant within the ambulance would provide an alternative to the current default, which is for the baby to travel unrestrained in a parent's arms. A person experienced in implementation of the SD-1 can secure a CRS in under 2 minutes, it has been shown to limit the movement and rotation of the bucket (reducing the risk of infant injury) and is fabricated using components that meet or exceed national recommendations for pediatric ambulance transport. This product, in its current form, makes significant progress towards the actual implementation of a device that allows for the safe and easy transport of infants in their CRS during non-emergent ambulance rides in the Capital Region.

References

- [1] J. M. Rippe, “Injury Prevention: A Medical and Public Health Imperative,” vol. 4, no. 1, pp. 6–7, 2010, doi: 10.1177/1559827609348690.
- [2] N. N. Borse, J. Gilchrist, A. M. Dellinger, R. A. Rudd, M. F. Ballesteros, and D. A. Sleet, “CDC Childhood Injury Report: Patterns of Unintentional Injuries among 0 -19 Year Olds in the United States, 2000-2006.,” Centers for Disease Control and Prevention, Atlanta (GA), 2008.
- [3] L. K. Lee, C. A. Farrell, and R. Mannix, “Restraint use in motor vehicle crash fatalities in children 0 year to 9 years old,” vol. 79, no. 3 Suppl 1, pp. S55–S60, Sep. 2015, doi: 10.1097/TA.0000000000000673.
- [4] M. Grivna, H. O. Eid, and F. Abu-Zidan, “Pediatric and youth traffic-collision injuries in Al Ain, United Arab Emirates: a prospective study,” vol. 8, no. 7, p. e68636, 2013, doi: 10.1371/journal.pone.0068636.
- [5] L. L. Wolf et al., “Factors Associated with Pediatric Mortality from Motor Vehicle Crashes in the United States: A State-Based Analysis,” vol. 187, pp. 295-302.e3, 2017, doi: 10.1016/j.
- [5] L. L. Wolf et al., “Factors Associated with Pediatric Mortality from Motor Vehicle Crashes in the United States: A State-Based Analysis,” vol. 187, pp. 295-302.e3, 2017, doi: 10.1016/j.jpeds.2017.04.044.
- [6] B. L. Watanabe, G. S. Patterson, J. M. Kempema, O. Magallanes, and L. H. Brown, “Is Use of Warning Lights and Sirens Associated with Increased Risk of Ambulance Crashes? A Contemporary Analysis Using National EMS Information System (NEMSIS) Data,” vol. 74, no. 1, pp. 101–109, 2019, doi: 10.1016/j.annemergmed.2018.09.032.
- [7] “Overview of Motor Vehicle Crashes in 2019.” Dec. 01, 2020.

- [8] (EMSC) Emergency Medical Services for Children and J. H. University, “The Do’s and Don’ts of Transporting Children in an Ambulance,” 2000.
- [9] J. O’Neil, G. K. Steele, E. Weinstein, R. Collins, J. Talty, and M. J. Bull, “Ambulance Transport of Noncritical Children: Emergency Medical Service Providers’ Knowledge, Opinions, and Practice,” vol. 53, no. 3, pp. 250–255, 2014, doi: 10.1177/0009922813517168.
- [10] Working Group from Community, Medical, Emergency Organizations, and Federal Agencies and Maryn Consulting, “Working Group Best-Practice Recommendations for the Safe Transportation of Children in Emergency Ground Ambulances,” U.S. Department of Transportation, National Highway Traffic Safety Administration, Sep. 2012. doi: <https://doi.org/10.1177/0009922813517168>.
- [11] Standard No. 213; Child restraint systems. 49 CFR § 571.213. 2017.
- [12] A. J. SPANIER, D. MERCANTE, and B. M. BARKEMEYER, “Child safety seat knowledge among postpartum mothers in an urban setting,” vol. 95, no. 9, pp. 1017–1021, 2002, doi: 10.1097/00007611-200209000-00018.
- [13] Z. F. Meisel, J. M. Pines, D. Polsky, J. P. Metlay, M. D. Neuman, and C. C. Branas, “Variations in Ambulance Use in the United States: The Role of Health Insurance: HEALTH INSURANCE AND AMBULANCE USE,” vol. 18, no. 10, pp. 1036–1044, 2011, doi: 10.1111/j.1553-2712.2011.01163.x.
- [14] J. Seim, “The Ambulance: Toward a Labor Theory of Poverty Governance,” vol. 82, no. 3, pp. 451–475, 2017, doi: 10.1177/0003122417702367.
- [15] M. W. Dailey, “Video Meeting,” Mar. 08, 2021.

- [16] "U.S. Health Insurance Coverage in 2020: A Looming Crisis in Affordability; Findings from the Commonwealth Fund Biennial Health Insurance Survey, 2020;2020 SRI R4050-121.36348," 2020.
- [17] C. King, "Disparities in access to preventive health care services among insured children in a cross sectional study," *Medicine*, vol. 95, (28), 2016
- [18] Ferno International "Model 678 Pedi-Mate," 2012. (Online) (accessed Mar. 22, 2021).
- [19] Quantum EMS "ACR4 (Ambulance Child Restraint) Q-ACR4" 2012. (Online) (accessed Mar. 22, 2021).
- [20] P. Barry and A. Leslie, "Paediatric and Neonatal Critical Care Transport", BMJ Books, 2003.
- [21] "Pediatric Restraint, Burgundy, 19 in Width" *Grainger*. [Online]. [Accessed: 24-Mar-2021].
- [22] "Quantum Ambulance Child Restraints (ACR). " *Life*. [Online]. [Accessed: 24-Mar-2021].
- [23] "49 CFR § 571.213 - Standard No. 213; Child Restraint Systems." Legal Information Institute, Legal Information Institute, www.law.cornell.edu/cfr/text/49/571.213.
- [24] Cripton, Peter A., et al. "Bicycle Helmets Are High Effective at Preventing Head Injury During Head Impact: Head-Form Accelerations and Injury Criteria for Helmeted and Unhelmeted Impacts." *Accident Analysis and Prevention*, vol. 70, Elsevier Ltd, 2014, pp. 1–7. [Online] [Accessed: 8-June-2021]
- [25] M. D. Eager and C. Chapman, "Why Bounce is Bad," in *National Playground Conference*. [Web]. New South Wales: Kidsafe, 2004. Available: Research Gate, https://www.researchgate.net/publication/259560464_Why_Bounce_is_Bad. [Accessed: 8 June 2021].

[26] *Driver's Mistakes When Installing Child Seats - Nhtsa.gov.*

www.nhtsa.gov/sites/nhtsa.gov/files/811234.pdf.

Appendix B

Who We Are

We are Stork, a company dedicated to safely transporting infants. Our device can universally secure Rear Facing Child Restraint Systems to an ambulance's cot efficiently and effectively.

Contact Us

Stork: Biomedical Engineering Capstone Group 1
807 Union Street
Schenectady, NY 12308
Email:
rogoffk@union.edu
kohlert@union.edu
buchanl2@union.edu
millerm3@union.edu

Rear-Facing Child Restraint System Securement Device



STORK

Stork

Table of Contents

Design Overview.....	1
Installation Steps.....	2
Device-Cot Attachment.....	2
Lap-Belt Attachment.....	3
Rear-Loop Attachment.....	4
Installation Checklist.....	5

Installation Checklist

- Ensure all straps are secured to the aluminum base in the proper arrangement
- Place the aluminum base underneath the center of the ambulance cot with the orange rear-strap oriented towards the head of the cot. Secure the black strap across the bed of the cot and tighten
- Place RF-CRS on the ambulance cot. Attach the blue belt-path strap across the belt path of the CRS and tighten
- Run the orange loop strap around the front of the RF-CRS and feed through the rear orange strap attached to the aluminum base. Tighten accordingly
- Pull all straps taught and perform the 1" movement test to ensure RF-CRS securement

Stork

5

Rear-Loop Attachment

The final attachment used to secure the RF-CRS to the ambulance cot is the Rear-Loop Attachment. The following steps are used to implement this attachment:

1. Run the orange loop-strap around the RF-CRS with the rubberized portion up against the front plastic ledge
2. Feed the rear-strap (orange) along the back of the ambulance cot. Guide the buckle of the orange loop-strap through the loop of the rear-strap and tighten
3. Check to make sure the RF-CRS is level on the ambulance cot
4. Tighten the rear-strap along the back of the cot until taught



5. Perform 1" movement test to ensure the RF-CRS is attached securely

4

Design Overview

Base Design



This base is the attachment point for all straps used to secure the RF-CRS to the ambulance cot. It is composed of an aluminum alloy for optimal strength and longevity.

The slots are designated to the following straps:

- Top: Rear-Loop Strap (Orange)
- Middle L/R: Device-to-Cot Strap (Black)
- Outer L/R: Lap-Belt Strap (Blue)

Strapping Pattern

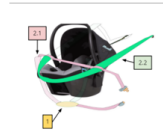

The following strapping pattern is used to secure the RF-CRS to the ambulance cot.

The blue strap utilizes the existing belt path of the CRS while the orange strap wraps around the front of the CRS to prevent tipping.

1

Appendix C

$$HIC = \left[\frac{1}{t_2 - t_1} \int_{t_1}^{t_2} a dt \right]^{2.5} (t_2 - t_1)$$

Formula 1: The formula used to calculate the HIC around the maximum force exposure to determine the likelihood of a head injury [24].

Appendix D

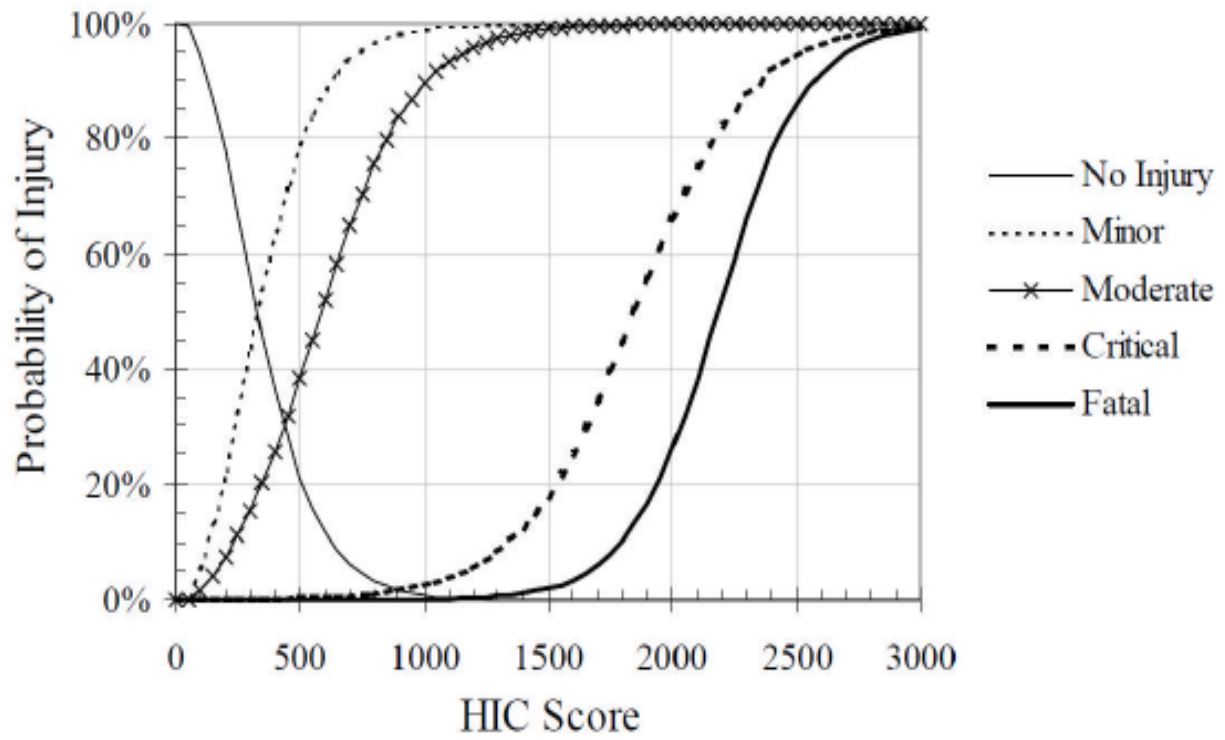

Figure 18: The plot that is used to determine the likelihood of a head injury based on the HIC score calculated from Formula 1. A score of 4, as was used in the example above, indicated an extremely low chance of a head injury. [25]

HIC Evaluations

Max acceleration: 4.32 g

Trial 1.1a

HIC:0.6154

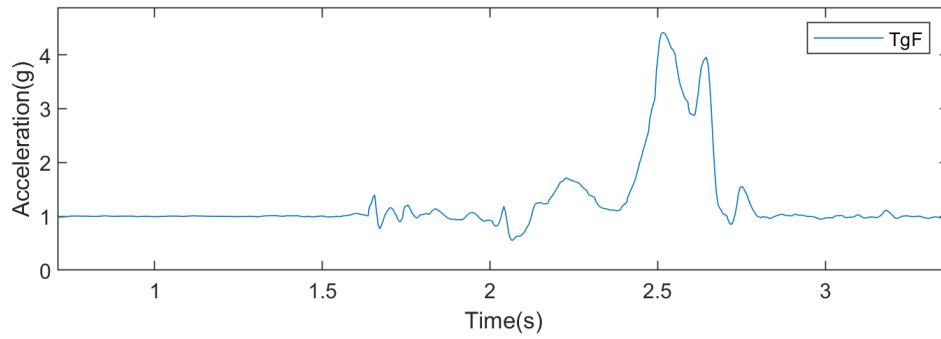
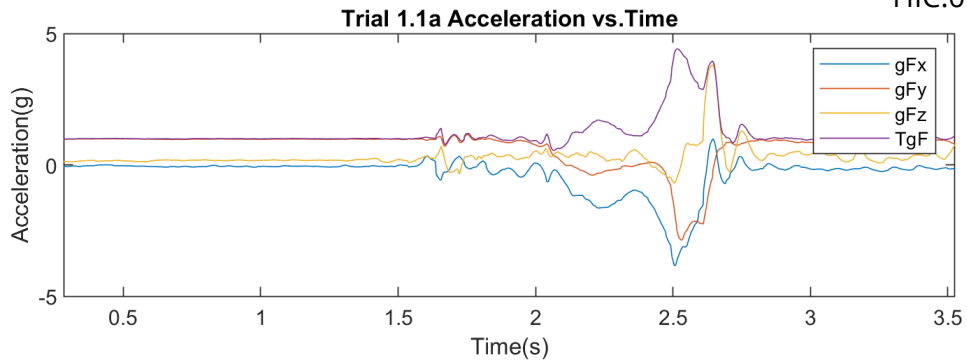

Trial 1.1b

Max acceleration: 9.852 g

HIC:4.5699

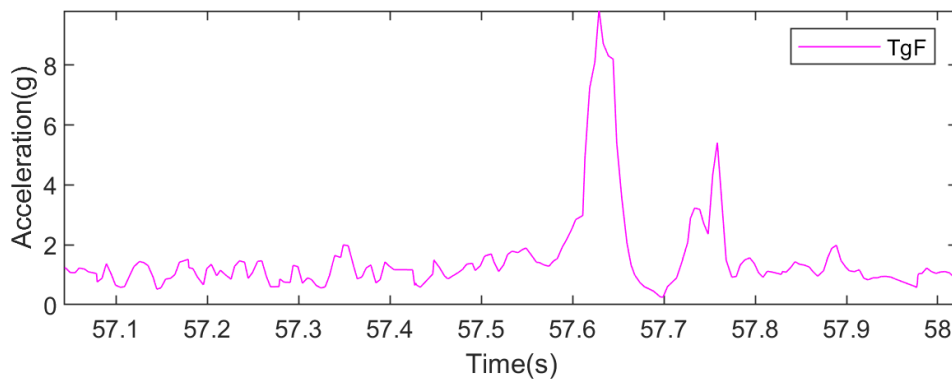
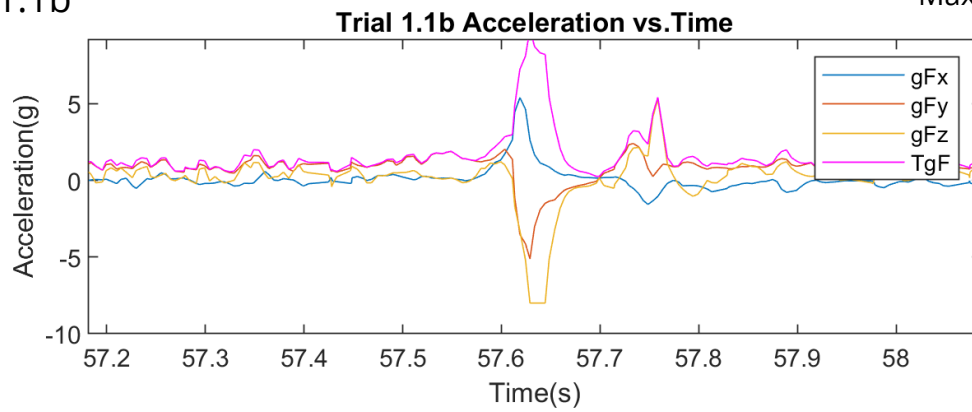

Trial 1.1c

Max acceleration: 10.579, HIC=5.4601

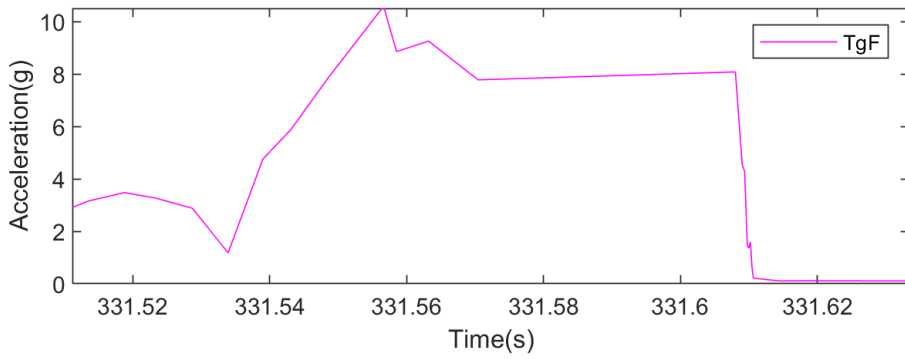
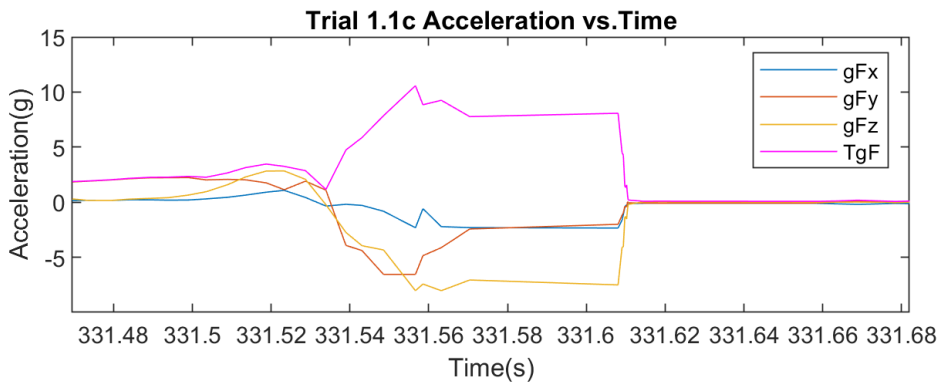

Trial 1.2a

Max acceleration 5.185, HIC =0.9183

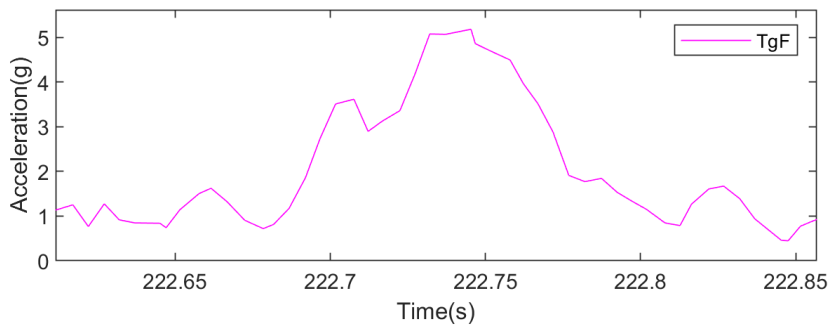
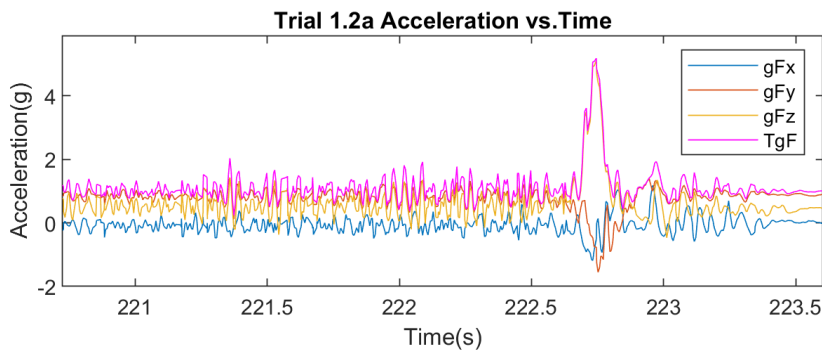

Trial 1.2b

Max acceleration: 7.579 , HIC 2.3720

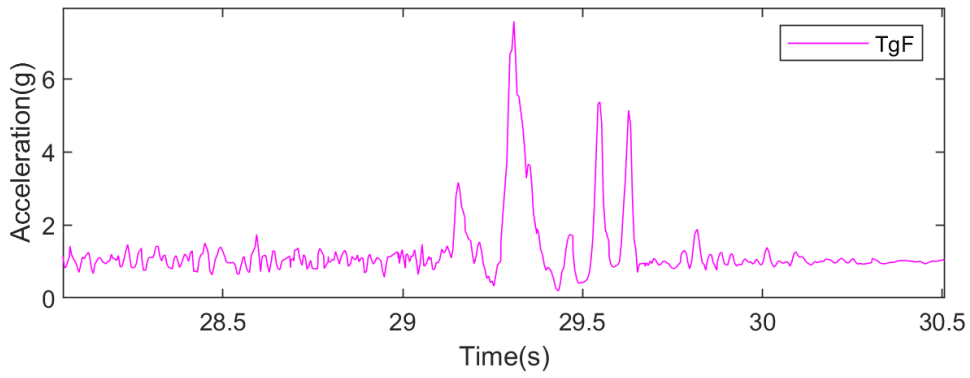
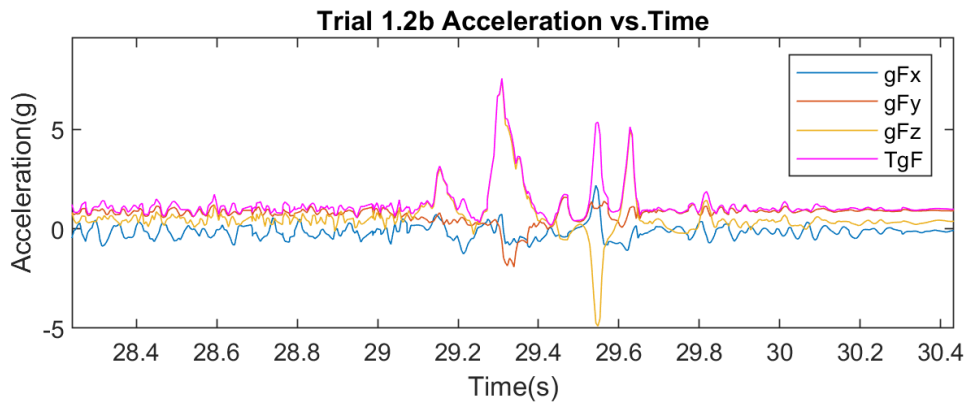

Trial 1.2c was not recorded

Trial 2.1a

Max acceleration: 9.743 HIC 4.4445

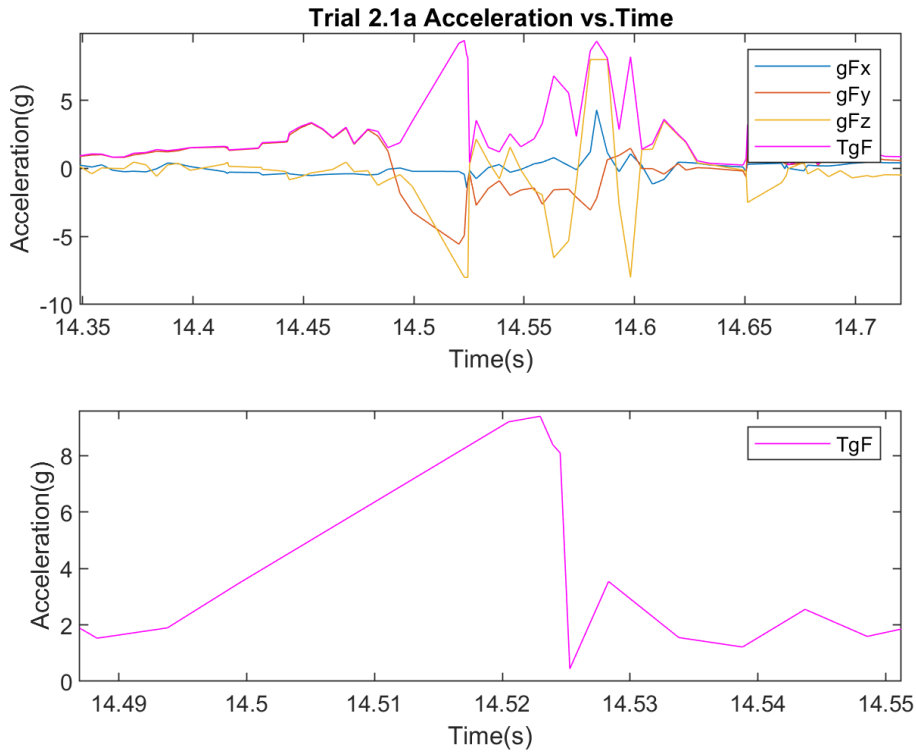

Trial 2.1b

Max acceleration: 11.341 HIC 6.4971

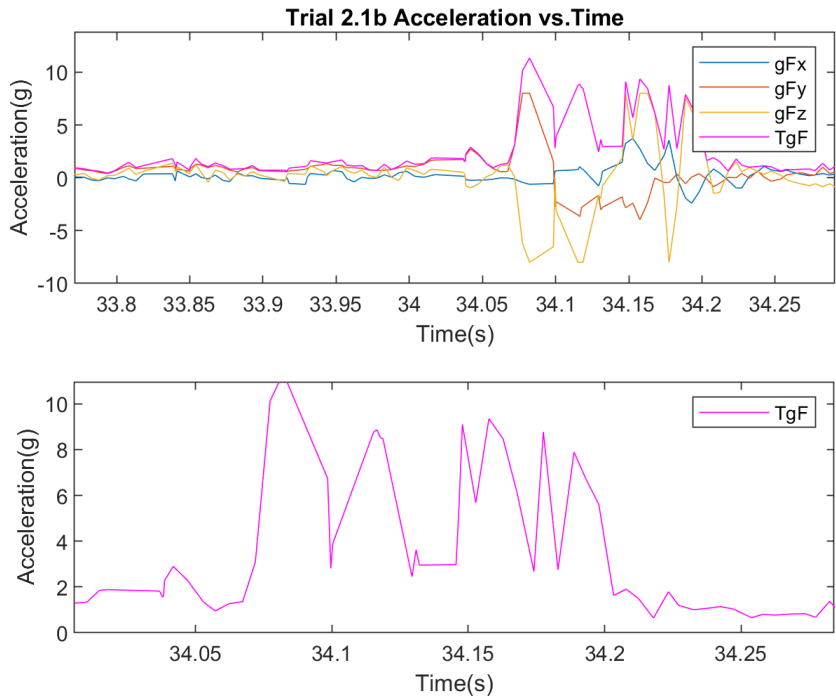

Trial 2.1c

Max acceleration: 9.872 HIC 4.5931

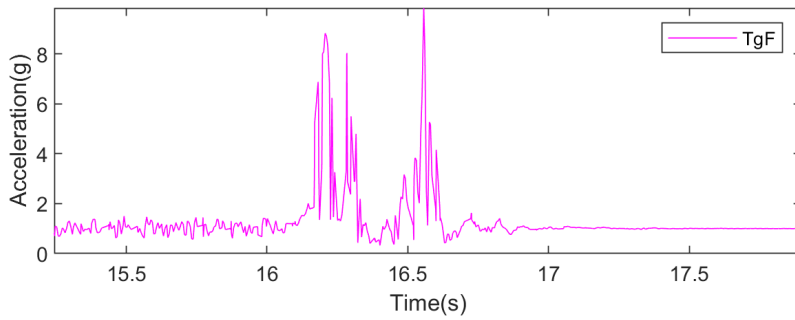
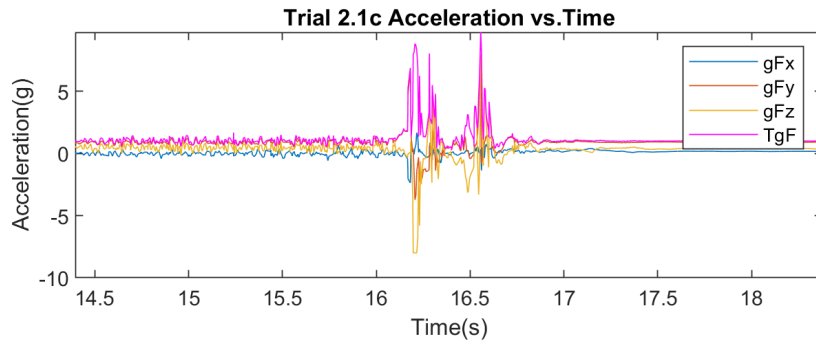

Trial 2.2a

Max acceleration: 9.258 HIC=3.9119

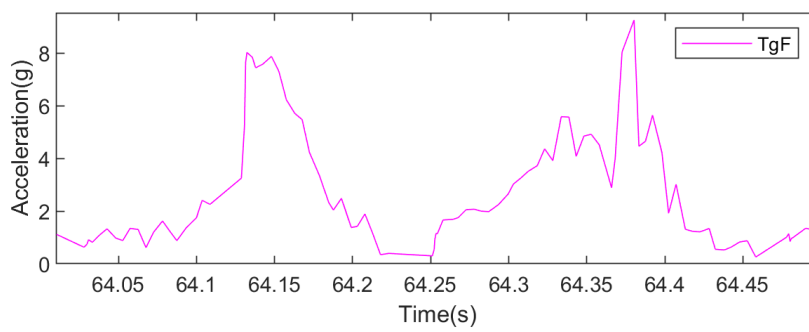
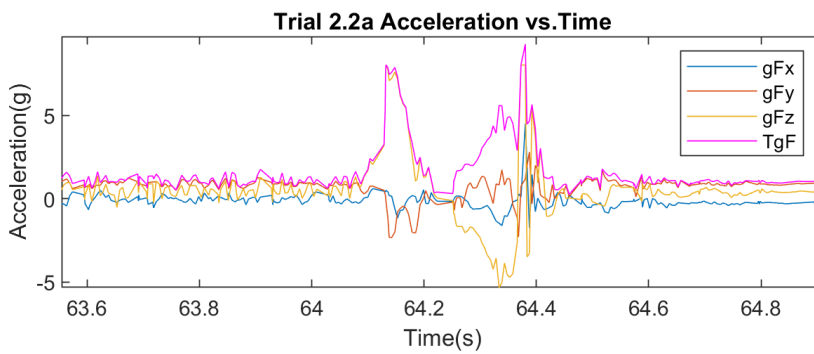

Trial 2.2b

Max acceleration: 5.734 HIC =1.1810

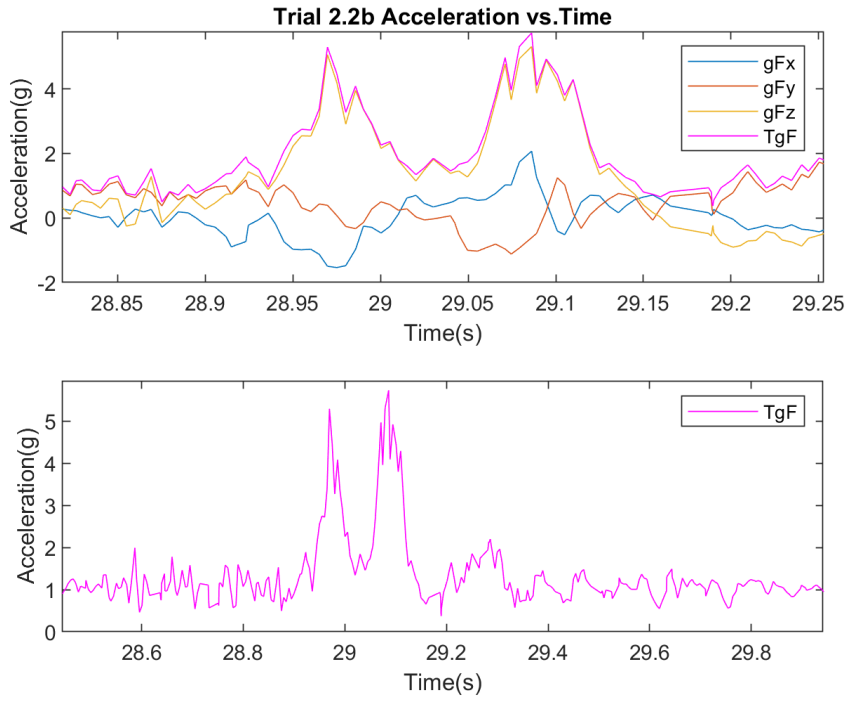

Trial 2.2c

Max acceleration: 5.973 HIC 1.3079

